

M600/1-600-3S

Optimum processing
of large-volume chips
at **low investment costs**

ALL OF YOUR REQUIREMENTS ARE IN EXPERT HANDS WITH US.

As an owner-managed company, we offer you personal consulting, short reaction times and customized solutions. Combined, of course, with comprehensive services and first-class quality made in Bavaria.

CORE COMPETENCIES

- Shredding machines
- Plant engineering
- Service

We are ready for your challenges.

WELCOME TO ERDWICH

SWARF-SHREDDER WITH 3 SCREW FEEDER M600/1-600-3S



The development of the innovative M600/1-600-3S Shredding machine with screw feed and integrated contaminant handling is based on many years of practical experience. Voluminous chips are the result of the occasionally very large feed quantities. The knowledge gained from shredding problematic solid parts contributes to our professionalism.

THE ADVANTAGES AT A GLANCE

- Effective equalization of the chippings in front of the cutting unit by 3 integrated frequency converter-operated screw conveyors the feed hopper
- Solid single-shaft technology with integrated foreign matter ejection flap ensures smooth system operation
- Automatic separation of impurities from the actual material flow into the on-site coarse parts container and discharge of the shredded chips into the undermounted chip conveyor
- With an additional vibro rod sizer, a further Separation of impurities into coarse and fine parts is achieved
- Intelligent system control with reversing operation for automatic detection of solid parts

In many metal processing companies, decentralized chip disposal is not possible due to the local structure or for reasons of space. The material supply is often limited to certain container sizes. An expansion so that the material can be fed into a machine at once, is usually associated with high investment costs and is therefore not economically feasible.

The chip shredder M600/1-600-3S with the innovative 3-screw feed was designed exactly for these purposes.



ERDWICH ZERKLEINERUNGS-SYSTEME GMBH

Gewerbestrasse 6
86859 Igling
GERMANY

Tel.: +49 (0)8191 - 96 52 - 0
E-Mail: infoline@erdwisch.de

www.erdwisch.com

**OUR ALL-ROUNDER IN CHIP PROCESSING:
LARGE-VOLUME FEEDING AND
PERFECT SEPARATION OF IMPURITIES
IN CONTINUOUS OPERATION**

www.erdwisch.com

ADVANTAGES AND TECHNOLOGY



3-SCREW-SWARF-SHREDDER. RECYCLING AT ITS BEST.



LARGE-VOLUME FEED AND PERFECT CONTAMINANT SEPARATION IN CONTINUOUS OPERATION

With the shredder M600/1-600-3S, ERDWICH has developed an innovative solution that enables companies in chip-removing production to process their chip volume very reliably.

Thanks to the large feed hopper, up to 800 liters of material can be dumped directly into the shredder using a forklift or a tilt-and-dump device. The rotating frequency-controlled feed screws guide the material slowly and evenly into the cutting unit.

Despite the homogeneous chip structure, there are often impurities or solid parts in the material, which can lead to significant damage to the cutting mechanism and subsequent units. Therefore, the ERDWICH innovation is equipped with a pneumatically driven discharge flap, which ensures reliable ejection of even more complex impurity geometries guaranteed to be process-reliable.

The ERDWICH chip shredders, with their combination of a large loading hopper and compact shredding machine, are the ideal solution for businesses with increased feeding volumes

Throughput rates:

- Steel chips up to approx. 400 kg/h*
- Aluminium chips up to approx. 300 kg/h*

*dependent on chip dimension, structure and material

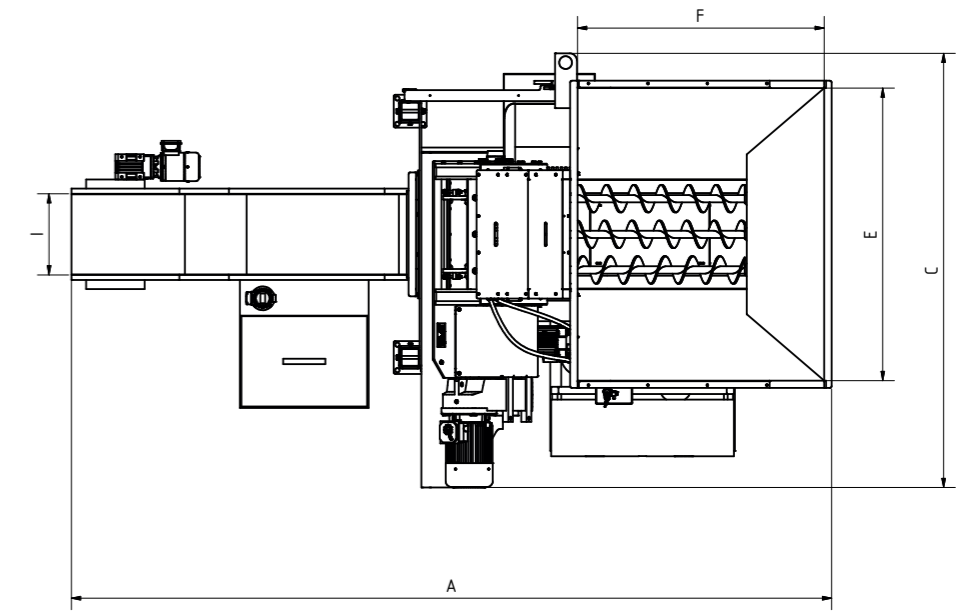
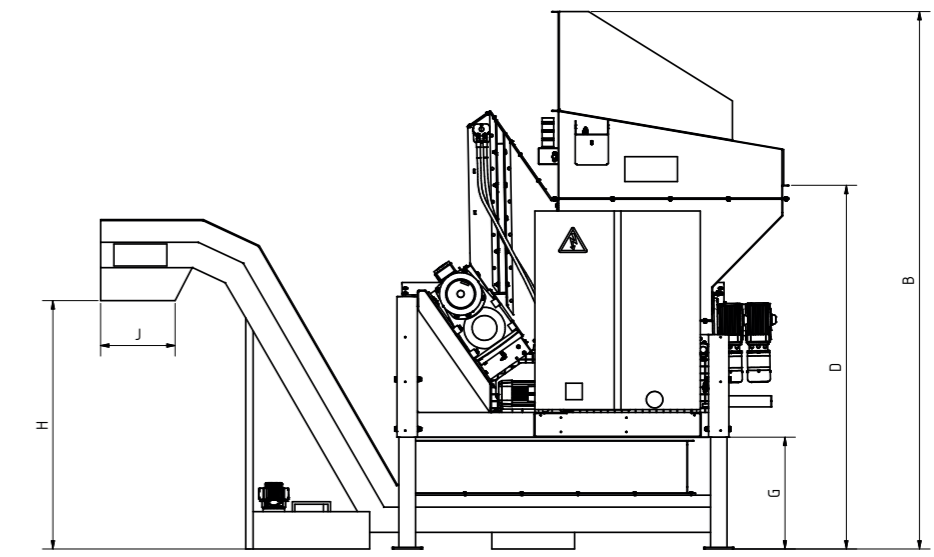
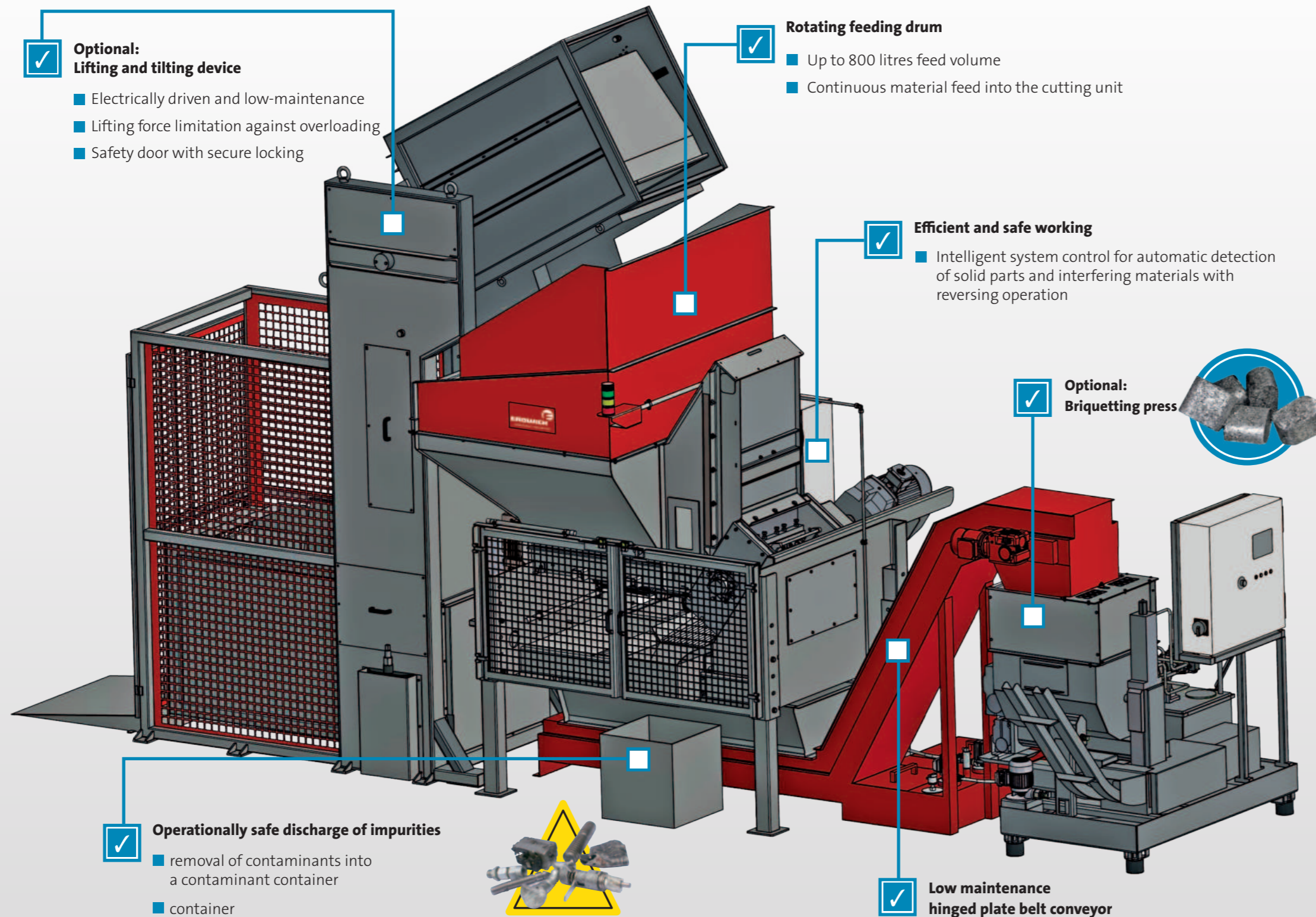

TECHNICAL DATA

Type	Number of shafts	Drive power in kW	Rotor length / diameter (mm)	Weight in kg	Cutting width in mm
M600/1-600-3S	1	7,5	600 x Ø 220	2.500	25

Dimensions	Dimension	M600/1-600-3S
Total length A	mm	4.160
Total height B	mm	3.250
Total width C	mm	2.375
Feed height hopper D	mm	2.200
Feed width hopper E	mm	1.600
Feed length hopper F	mm	1.350
Frame height G	mm	675
Conveyor discharge height H	mm	1.500
Discharge width conveyor I	mm	450
Discharge length conveyor J	mm	450
Max. hopper volume	liter	800